

**4-LEG INTERSECTION**  
NOT TO SCALE

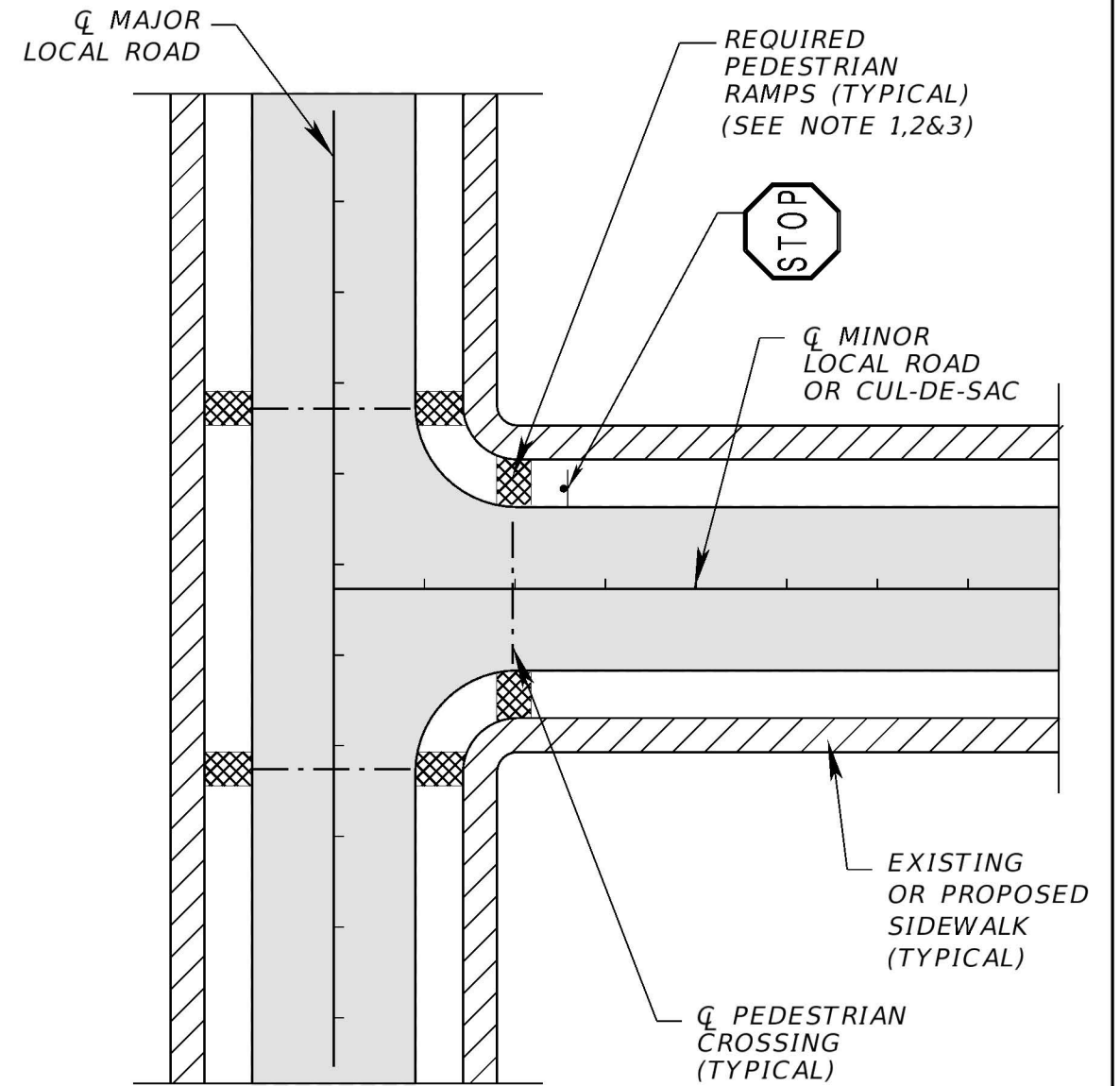

**3-LEG INTERSECTION**  
NOT TO SCALE

**NOTES:**

1. PEDESTRIAN RAMPS MUST BE COMPLIANT WITH THE AMERICANS WITH DISABILITIES ACT (ADA).
2. THE SIDEWALK RAMPS MUST BE ORIENTED SO THAT THE PEDESTRIAN CROSSING CENTERLINE IS PARALLEL TO THE ADJACENT ROAD.
3. SIDEWALK CURB RAMPS MUST BE SEPARATED SO THAT THE DETECTABLE WARNINGS ARE INDEPENDENT OF EACH OTHER AND DO NOT OVERLAP.

LAST REVISION 12/22/22	REVISION	DESCRIPTION	ORIGINAL SIGNED AND SEALED DOCUMENTS ARE RETAINED IN THE HILLSBOROUGH COUNTY ARCHIVE FILES	 <b>Hillsborough County Florida</b> EST. 1854	<b>PEDESTRIAN RAMP CONFIGURATION FOR LOCAL ROADS</b>	INDEX PRC-001	SHEET 1 of 1
---------------------------	----------	-------------	--	---	--	------------------	-----------------